

White Paper

Measuring infrared radiation using trinamiX lead sulfide and lead selenide detectors



Figure 1: trinamiX lead sulfide and lead selenide detectors

April 28, 2020 – Ludwigshafen, Germany – Accurate detection and classification of substances and materials is critical for today's ever-growing needs related to both automation and increased safety. Optical sensing technologies are at the forefront when it comes to such applications because of their fast, robust and contactless measuring abilities

Lead sulfide (PbS) and lead selenide (PbSe) infrared detectors are especially attractive because of their wide useful wavelength range. This becomes apparent by looking at Fig. 2, which shows the wavelength coverage of the most common optical detector families, together with the positions of important spectral features regarding humidity, plastic materials, and gases. Compared to other detector families, in

What are PbS and PbSe detectors?

Polycrystalline lead sulfide (PbS) and lead selenide (PbSe) detectors are thin film semiconductor devices that have been in use as infrared (IR) detectors for almost a century owing it to their versatility and wide wavelength coverage. PbS detectors respond to light with wavelengths between 1 and 3 μm and are applicable for near infrared (NIR) applications. PbSe detectors extend into the mid infrared (MIR), covering applications from 1 to 5 μm .

Both detector types utilize the photoconductive effect where exposure to infrared radiation causes a decrease of the resistance of the active area as a function of the radiation intensity.

Depending on the application, photoresistors are a viable alternative to photodiodes both in terms of performance and cost.

particular InGaAs photodiodes, the spectral coverage of PbS and PbSe allows for a much wider field of possible applications.

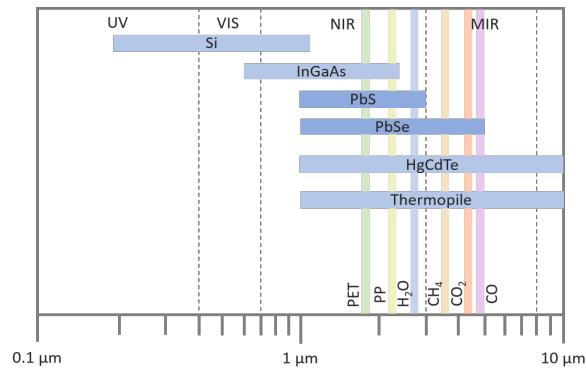

Figure 2: Spectral response ranges of typical NIR detectors and example wavelengths of interest

Lead sulfide is excellent for detecting O-H and C-H bonds as these bonds have absorptions characteristics that are very well pronounced in the NIR range. This allows the afore-mentioned detection and classification of materials and substances such as textiles, polymers, fatty acids or alcohols.

Being able to detect infrared radiation up to 5 µm, lead selenide is useful in gas sensing applications. Its excellent responsivity around 4 µm makes it well suited for CO₂ detection, e.g. to monitor ambient air quality or breath gas analysis. Other gases that can be detected by PbSe include CH₄, H₂O, NO, and N₂O.

Furthermore, it is possible to use both PbS and PbSe as flame and spark sensors for detecting characteristics of flames, as well as for fire prevention and detection purposes.

Key advantages

The major advantage of trinamiX PbS and PbSe detectors is their high detection capability under room temperature conditions as compared to other detectors in the same wavelength range.

The price to performance ratio is one of the best in the market when factoring in high detectivity to the relatively low cost per active area. This makes PbS and PbSe a more sensible option compared to compound-based photodiodes such as InGaAs, which have a higher cost-per-active area and often require thermoelectric cooling to reach the required performance. While thermopiles and HgCdTe detectors have a similarly broad wavelength coverage as Pbs and PbSe, they are either much less sensitive or much more expensive, respectively.

These factors make PbS and PbSe detectors a very compelling choice where NIR/MIR detection capabilities with an attractive price-to-performance ratio are required.

Hertzstück™ detectors by trinamiX

The Hertzstück line of detectors by trinamiX improves the PbS and PbSe detector designs currently on the market by introducing a thin film layer that encapsulates the active area and electrodes, allowing the usage of these detectors in bare chip form without the need for an additional hermetically-sealed packaging. This in turn enables miniaturization of sensor systems and maximization of the field-of-view, which is often limited by TO housing caps or entrance windows in traditional packages.

Currently, trinamiX offers detectors with square or rectangular active areas from 0.5 mm x 0.5 mm to 10 mm x 10 mm. The bare chips are pick-and-

place compatible and fully wire bondable. Aside from bare chip detectors, trinamiX also offers these detectors in standard TO-5 and TO-8 packages to accommodate customer wishes and compliance with their existing processes and equipment.

New products to be introduced are pre-bonded bare chips on thin adapter PCBs that can be soldered to system PCBs (see Fig. 3) and thermoelectrically cooled (TEC) detectors in TO packages. The latter provide an additional performance gain in critical applications such as gas sensing or spectral analysis.

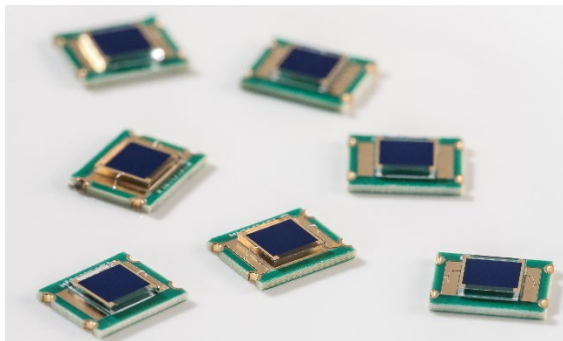

Figure 3: Pre-bonded Hertzstück bare chip detectors

Common to the manufacturing process of the trinamiX Hertzstück detectors is the flexibility to adjust sensor geometries to customer needs at moderate non-recurring costs. This allows trinamiX to match sensor dimensions almost exactly to an optical system, e.g. to the beam profile of a spectrometer. Such an approach makes it possible to fine-tune response and noise characteristics of a system.

Working with PbS and PbSe photoresistors

There are some peculiar characteristics that need to be considered when working with PbS and PbSe detectors, especially by users more accustomed to photodiodes.

Photoresistors are passive devices which unlike photodiodes cannot be operated in photovoltaic mode - they always require a bias voltage. The second key difference can already be deduced from their name: they behave like resistors, not diodes. Consequently, there is no p-n junction, no junction capacitance, and no polarity.

Fig. 4 shows an exemplary front-end amplifier circuit for photoconductors such as PbS and PbSe.

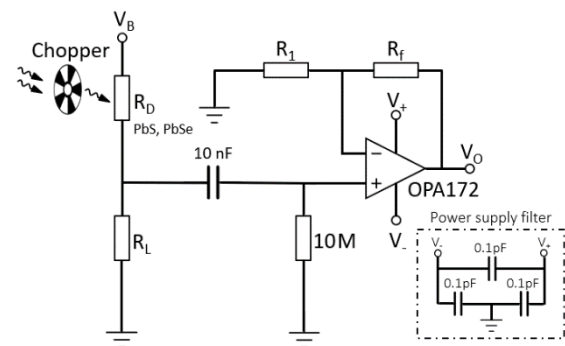

Figure 4: Example readout circuit for PbS and PbSe detectors

Together with a matched load resistor R_L the detector forms a voltage divider, driven by a bias voltage V_B , typically up to a few 10 V. The value of the load resistor should be similar to the dark resistance R_D of the detector for maximum detection performance. PbS and PbSe photoresistors exhibit $1/f$ noise and can be affected by thermally induced drift of their dark resistance. They are therefore ideally used with optical choppers or with modulated or transient light sources such as flickering flames.

The voltage divider output signal is amplified by an AC coupled operational amplifier with low input voltage noise as a function of a gain R_1 and feedback resistor R_f . Depending on the application, further filtering in the frequency domain, rectification or processing by a lock-in

amplifier are typical building blocks of a readout electronics system.

In the transition from using conventional photodiode detectors to employing photoresistors, the key points to consider are the different driving and amplifier circuit design and the recommendation to use modulated light sources for best noise performance.

Summary

PbS and PbSe photo detectors can be used for a multitude of applications in the field of near and mid infrared sensing. High responsivity, usability at room temperature, and their wide wavelength coverage make them an excellent choice for moisture detection, flame and gas sensing as well as NIR spectroscopy.

Keeping the fundamental difference between photoresistors and photodiodes in mind, new users will easily profit from the potential offered by this type of detectors.

With the expert support of trinamiX in designing and optimizing readout electronics for PbS and

PbSe sensors, customers can truly focus on application design and get started quickly on product development.

trinamiX has built a new state of the art production plant, which allows significant R&D capabilities while offering high quantity production capacity. This allows trinamiX to tailor detector geometries and mounting setups to perfectly match specific customer needs and make these solutions readily available in large quantities.

Aside from the standard TO-packages the Hertzstück brand of detectors are also offered in wire bondable bare chip form with a patent pending thin-film encapsulation. This makes them suitable for use outside of bulky and expensive hermetic packages.

Thanks to improved design and manufacturing processes there are and will be compelling technical and cost reasons to choose PbS and PbSe detectors for many applications now and in the future.

About trinamiX:

trinamiX www.trinamixsensing.com is a wholly-owned subsidiary of BASF SE, the world's largest chemical company. Founded in 2015, the company has developed a wide-ranging portfolio of technologies and products around both infrared detection as well as 3D imaging and distance measurement employing a team of more than 100 experts across a wide range of scientific disciplines.

Sales contact

Christian Dörr

T: +49 621 60 97165

E: christian.doerr@trinamix.de

Media contact

Ines Kuehn

T +49 621 60-42082

E ines.kuehn@trinamix.de